



The New Generation.
Inspired by Architecture.



To make sure it stays that way, we have developed a solid surface that gives architects, designers and craftsmen the ultimate creative freedom: HI-MACS®. The material of the "New Generation". For your ideas, dreams and spaces.



We love architecture.
Because it's the stage
for our lives.
Because it gives us
fresh inspiration
each day to reinvent
our spaces.

HI-MACS® is growing into the material of choice for high-end interior design. Linear designs with precise edges, elegant curving forms and emotional lighting effects: almost anything is within reach for this material of possibilities.

Project: Private house in Termen, Switzerland – Design: Matthias Werlen Architektur AG – Fabrication: Zeiter + Berchtold AG – Photo: Thomas Andenmatten

Feel comfortable when in your stylish home

From the kitchen and bathroom to complete interior designs, from wide, open sweeping spaces to perfect solutions for the smallest details – HI-MACS® does much more than you might think, thanks to its excellent material properties, highly advanced manufacturing process and creative flexibility. The material adapts to your every vision, plan and requirement to meet each challenge head on – both today and tomorrow. This is what makes HI-MACS® the material of the future and the material of the "New Generation".

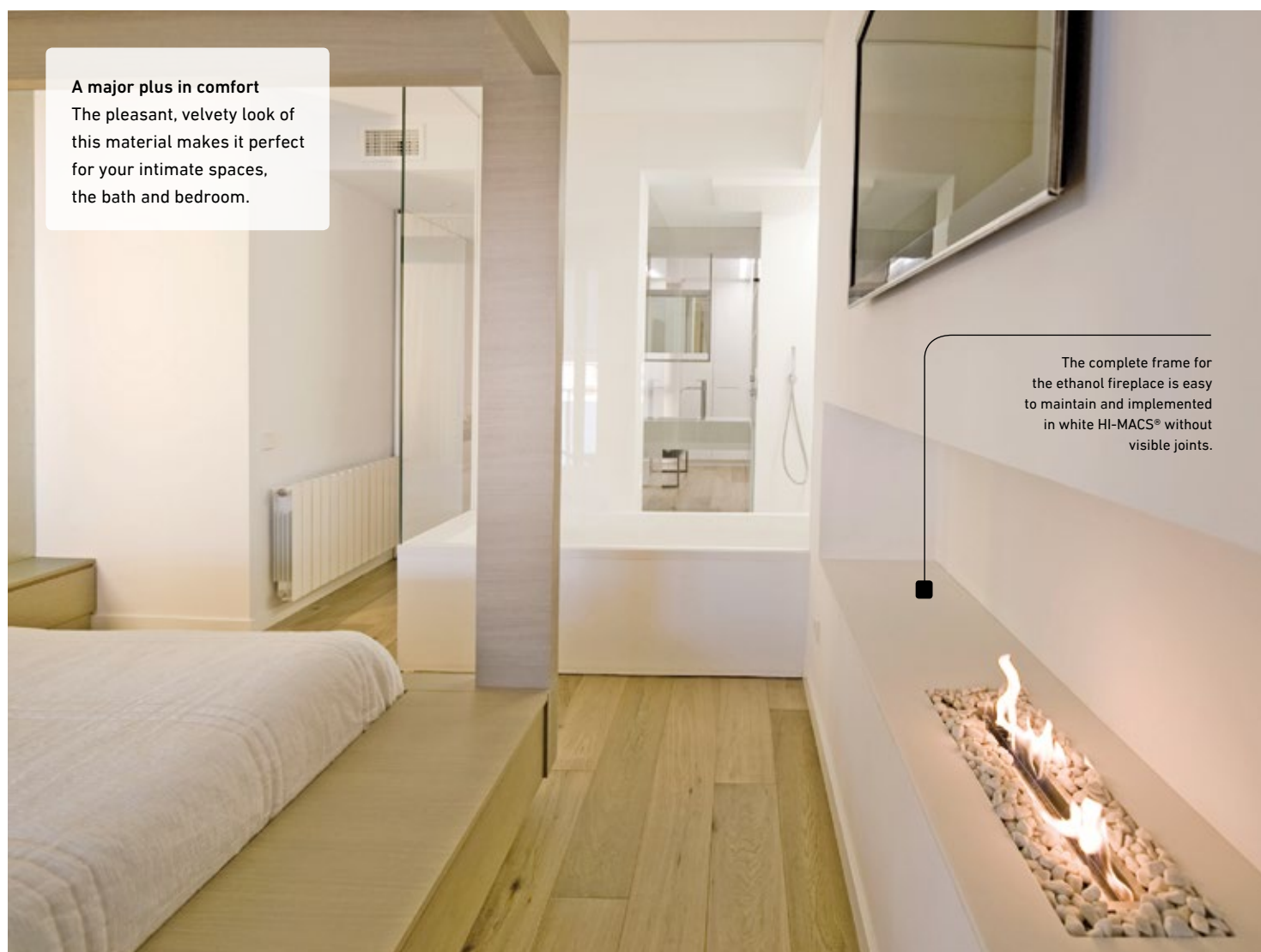

A major plus in comfort

The pleasant, velvety look of this material makes it perfect for your intimate spaces, the bath and bedroom.

The complete frame for the ethanol fireplace is easy to maintain and implemented in white HI-MACS® without visible joints.



The spacious working surface transitions fluidly from the kitchen into the eating area.

Robust elegance
Extremely lovely in living spaces, extremely durable in the kitchen. HI-MACS® mediates all desires perfectly, without making compromises.

Outstanding features abound. A compelling material.

HI-MACS® is an intelligent composition of acrylic, natural minerals and pigments that come together to provide a smooth, non porous and visually seamless surface which meets the highest standards for aesthetics, functionality and hygiene. Thanks in large part to its flexibility, HI-MACS® offers countless advantages over conventional materials.



Seamless perfection

HI-MACS® allows for visually seamless manipulation. Smooth integration enables large areas without visible joints or edges as well as flush mounting of sinks or bowls. Not only do objects made from this solid surface material appear to be works of art cast from a single mould, the material's seamless manipulation and non

porous nature create surfaces which are extremely hygienic, easy-to-clean and thus ideally suited for use in hospitals and laboratories. The seamless finish also allows for repair and replacement without a visible trace should any part of a HI-MACS® installation be damaged at any time.

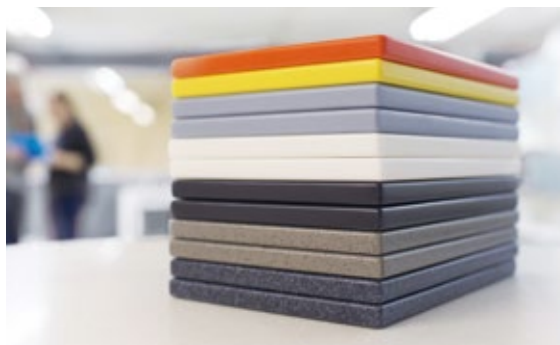

Unlimited colour spectrum

Along with choice of material, colour selection is a crucial factor when it comes to high-quality design. Elegant White, warm Toffee Brown, bold Orange, mystical Cima, translucent pastels or fine shimmer textures.

HI-MACS® offers a virtually limitless range of colours in many shades. More are being added every year, no matter what colour you choose, HI-MACS® remains 100% homogeneous.



Three-dimensional design

HI-MACS® boasts a simple heating process and three dimensional thermoforming capabilities. This allows for greater forming flexibility compared with other conventional materials so that spectacular ideas can quickly

take on a concrete shape. No radius, shape or angle is impossible. The logical conclusion: a material that moulds to your ideas and designs – not the other way around. Exactly how it should be.



Dramatic translucency

Certain colours and thicknesses of HI-MACS® exhibit a special translucency when exposed to light. Various textures and patterns can be built into the material to intensify the HI-MACS® translucency effect. Depending on the light source, pattern and design, spectacular cut-out effects

can add visual interest and create a completely new sense of space. The translucent properties of this solid surface material make it the perfect choice for lamps and illuminated furnishings.



Simple processing

Although HI-MACS® is almost as robust as stone, it can be worked in the same way as wood. Using conventional carpenters' tools, this solid surface material can be sawn, routed or drilled. It lends itself to the creation of an endless

variety of multi-dimensional forms and much, much more. No wonder most people working with the material have a background in woodworking and appreciate HI-MACS® as a natural partner for innovative ideas.

Shaping the future. In harmony with the environment.

Countless internationally recognised certificates attest to the fact that HI-MACS® has a strong focus on ecological aspects. Without exception, all HI-MACS® products are manufactured in accordance with the ISO 14001 environmental standard.

— **Composition:** aluminium trihydroxide, the main component of HI-MACS®, is a bi-product of aluminium production.

— **Manufacturing process:** The production of this material is marked by an excellent energy balance. In addition, HI-MACS® plants in Cheongju (Korea) and Atlanta (USA) meet all environmental standards.

— **Transport:** The material is transported from the USA to Europe exclusively by ship. Within Europe, HI-MACS® observes the Euro-5 standards for reduced particulate emissions. The partner-network of LG Hausys Europe is selected thoroughly: the transport partner for Europe guarantees recycling of wastewater, uses solar energy in the warehouse and trucks that run on gas. Therefore the LG Hausys-partner was awarded with the Green Truck Award 2013.

— **Processing:** The material allows for virtually waste-free processing.

— **Commitment:** LG Hausys conducts and publishes regular environmental audits along with energy consumption analyses. Thanks to the use of non-polluting fuels, greenhouse gas emissions have been cut by 15,000 tons per year since 2008.

— **Formaldehyde free:** Comprehensive examinations have been carried out by LG Hausys own laboratories as well as studies at reputable independent institutes. These studies have proven that following the curing process HI-MACS® material and adhesives are free from formaldehyde.

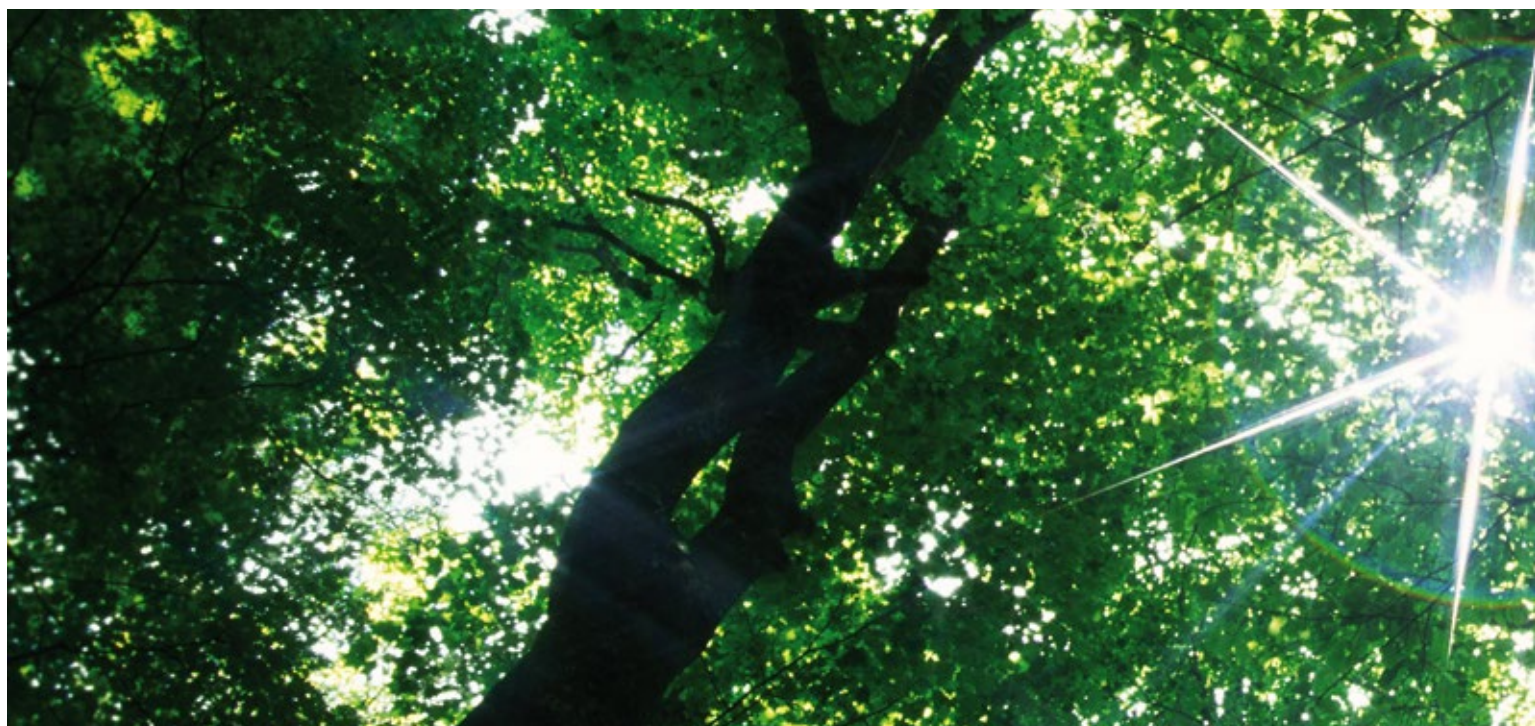



The Eden collection. Eco-friendly through and through.

The Eden colour collection by LG Hausys is the most environmentally friendly solid surface material available on the market today. This one-of-a-kind colour palette consists of up to 35% recycled materials and is available in 8 warm, natural shades.

The Eden collection has been recognized by the U.S. Scientific Certification System for the large proportion of recycled material it uses. Furthermore, projects made from HI-MACS® Eden are eligible for LEED (Leadership in Energy and Environmental Design) certification from the U.S. Green Building Council, and may receive up to 2 credits in various LEED categories. Another solid and sustainable reason to choose HI-MACS®.

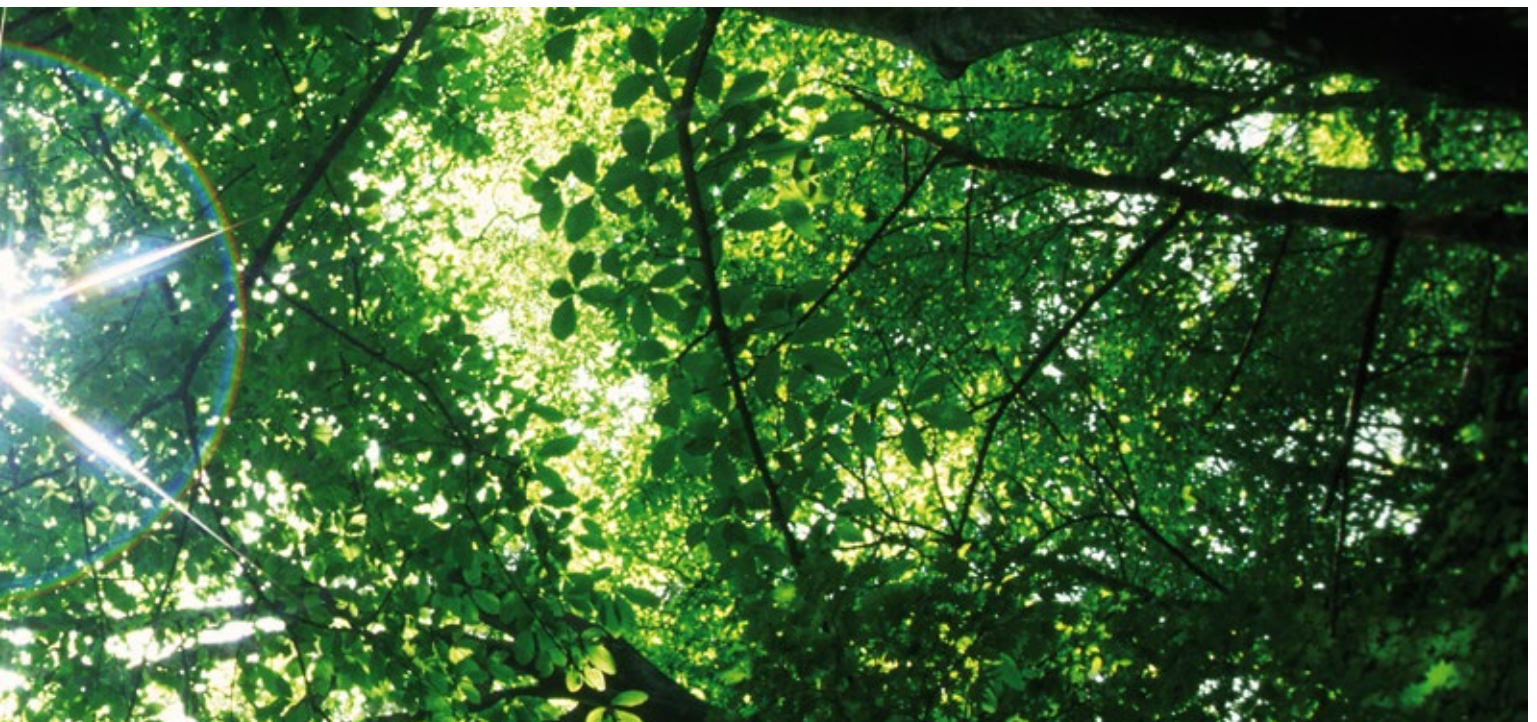

Advanced technology. For the New Generation.

HI-MACS® is manufactured using a modern production method which includes strict safety standards and the regular inspection of raw materials. A new generation technology, the thermal cure, brings the material to a high temperature. The temperature reached during the manufacturing process sets HI-MACS® apart from other solid surface materials and creates a denser, even more homogeneous, sturdy and durable surface – with a better heat resistance and superior thermoforming qualities. Proving once again that HI-MACS® lives up to its reputation as the material of the "New Generation".





HI-MACS®
Natural Acrylic Stone™

QUALITY CLUB

Committed to quality.

The HI-MACS® Quality Club is made up of experienced fabricators, processing plants and installation engineers. All members receive a top-quality individual training at an authorised Training Centre. All with the goal of ensuring that objects made from this solid surface material are created and processed under the highest quality conditions.

Loyalty is rewarded with a 15 Year Material Warranty* for material fabricated and installed by a member of the HI-MACS® Quality Club. End users also benefit from an extremely high standard for service quality, and can rest assured in the durability of their HI-MACS® product.

* not applicable to facade installations and disclaimer colours.



HI-MACS® is a true all-round talent in a number of market segments.

- Public buildings
- Facades and wall cladding
- Healthcare
- Educational institutions
- Shops & exhibitions
- Hotels
- Gastronomy
- Airports
- Marine industry
- Living spaces
- Kitchen
- Bath
- Furniture design



The wall appears to transition seamlessly into the ceiling, becoming one large installation from a single piece.

The favourite for grand ideas
The curved walls and furniture of this hotel room in Madrid are only possible because HI-MACS® is happy to deliver whatever curves you can dream up.

Project: Hotel Silken Puerta America, Spain – Design: Zaha Hadid Architects – Photo: diephotodesigner.de

Hotels

HI-MACS® is an excellent choice for hotels thanks to its class and elegance. It boasts an exceptional value for money, a long lifespan and a vast array of creative possibilities. So it's only logical that HI-MACS® is a trusted material in numerous examples of today's most sought-after hotels.



Highly functional and exceedingly beautiful facades have been designed since HI-MACS® S728 Alpine White, combined with KEIL inserts and a BWM structure, successfully passed all relevant ETA tests.

Project: Private House, Germany – Design: Dipl.-Ing. Volker Wiese – Kaden Klingbeil Architekten – Fabrication: Kiebitzberg GmbH & Co.KG – Klöpfer Surfaces – Photo: Dirk Wilhelmy

Facades and wall cladding

For the 13 selected colours for outdoor applications HI-MACS® offers a combined 5, 10 and 20 Year Warranty: 5 Year Warranty is issued on UV resistant colours for a tolerance of $\Delta E3$ to $\Delta E4$ and loss of gloss over 40%, a 10 Year Warranty on colour leaching and a 20 Year Warranty on

colour peeling, swelling or delaminating. The warranty is applicable after the first installation and is only valid for the sheet material; adhesives are excluded. The conditions for this warranty are based on practical experience and on-going tests.

Public buildings

HI-MACS® gives a significant boost to both design-related and functional possibilities. All kinds of ideas can be implemented with it, and even the most specific of requirements fulfilled. Opting for HI-MACS® is a safe decision in

the long term as well: the material undergoes all relevant product testing, meets the German Class B1 criteria for fire protection and boasts countless certificates which attests to its exceptional quality.



Milled inlays are set off to the best effect by dramatic backlighting.

An elegant HI-MACS® reception desk enhances the luxurious minimalist ambience.

Project: Porsche Museum, Germany – Design: Delugan-Meiszl ZT GmbH – Fabrication: GRAICHEN Bau- und Möbelwerkstätten – Klöpfer Surfaces – Photo: Zoëy Braun Fotografie



Illuminated displays show off antique paintings and HI-MACS® sheen.

Project: Schiller Museum, Germany – Design: COAST Office Architecture – Fabrication: Schreinerei Lell – Klöpfer Surfaces – Photo: David Franck



The pivotal point of the showroom: intricate circular latticework made from HI-MACS®.

All eyes over here: a streamlined display area deliberately directs the viewer's eye.

Project: Showroom ALV, Italy – Fabrication: Flusso, Facchinetti Group – Photo: Valter Baldan Fotografo

Shops and exhibitions

All high-traffic, high-strain areas require a highly functional, durable material. Stores and exhibition spaces are no exception. Fortunately, HI-MACS® has no trouble meeting all these criteria.



Project: Audi international Stand – Design: oettle ferber associates – Fabrication: Pfeiffer GmbH & Co. KG – Photo: Zooney Braun Fotografie

Gastronomy

Whether playful and romantic, super hip or classic cosmopolitan, HI-MACS® lets architects and designers create the mood of their choice. The properties of this solid surface material are as varied as the wishes of restaurant owners and their guests.



Project: Bar Counter, Slovakia – Design: Mgr. Art. Kristína Kremková – Fabrication: Kovovýroba Blecha – Photo: Roman Skyba



Stable substructure and illuminated design highlights all in one.

Gorgeous! This bar is magnificently stylish and functional. Water and a moist cloth are all that's needed to take care of HI-MACS® for years.

Project: Bar in Main Palais, Germany – Design: PurPur GmbH – Fabrication: Paul Schad Tischlerei GmbH – Klöpfer Surfaces – Photo: Thorsten Ruppert



Living spaces

From floors to walls, from the terrace to the mantelpiece: HI-MACS® turns living spaces into customized live-in landscapes that appear to come from a single cast.



The HI-MACS® fireplace: elegance and exceptional heat resistance in one.



An imaginative table that reaches towards the pool like a diving board, now a reality thanks to this flexible material.



The key ingredient: the right material. HI-MACS® is virtually everywhere in this kitchen. Its countertops, sink, drawers and appliance casings are made from the solid surface material.

Sinks are flush with the countertop.

Kitchen

HI-MACS® features a smooth, non porous and stain-resistant surface which is easy to clean and thus ideally suited for working with food. All installations created using this material are resistant to household chemicals. HI-MACS® also offers a wide range of matching sinks and makes it easy to create custom-made installations.

Project: Private House, Sweden – Fabrication: LG Collection – Photo: Focal Foto



Project: Berceki Kitchen, Spain – Fabrication: Realinox – Design: Mauel Menendez for Berceki

Bath

Thanks to its unique look, water-resistant surface, and pleasant feel, HI-MACS® is ideally suited for use in the bathroom. HI-MACS® is an extremely sanitary, easy-to-clean material with a large selection of wash basins to explore.

The perfect material for any bathroom
A square sink, fitted seamlessly into the counter, with stylish, flush furniture facings, a low-maintenance wall and tub cladding – all from one material: HI-MACS®



Project: Taskirdi, Belgium – Design: Joke Holvoet for Eift bvba – Fabrication: Eift bvba – Photo: Frederik Vercruyse

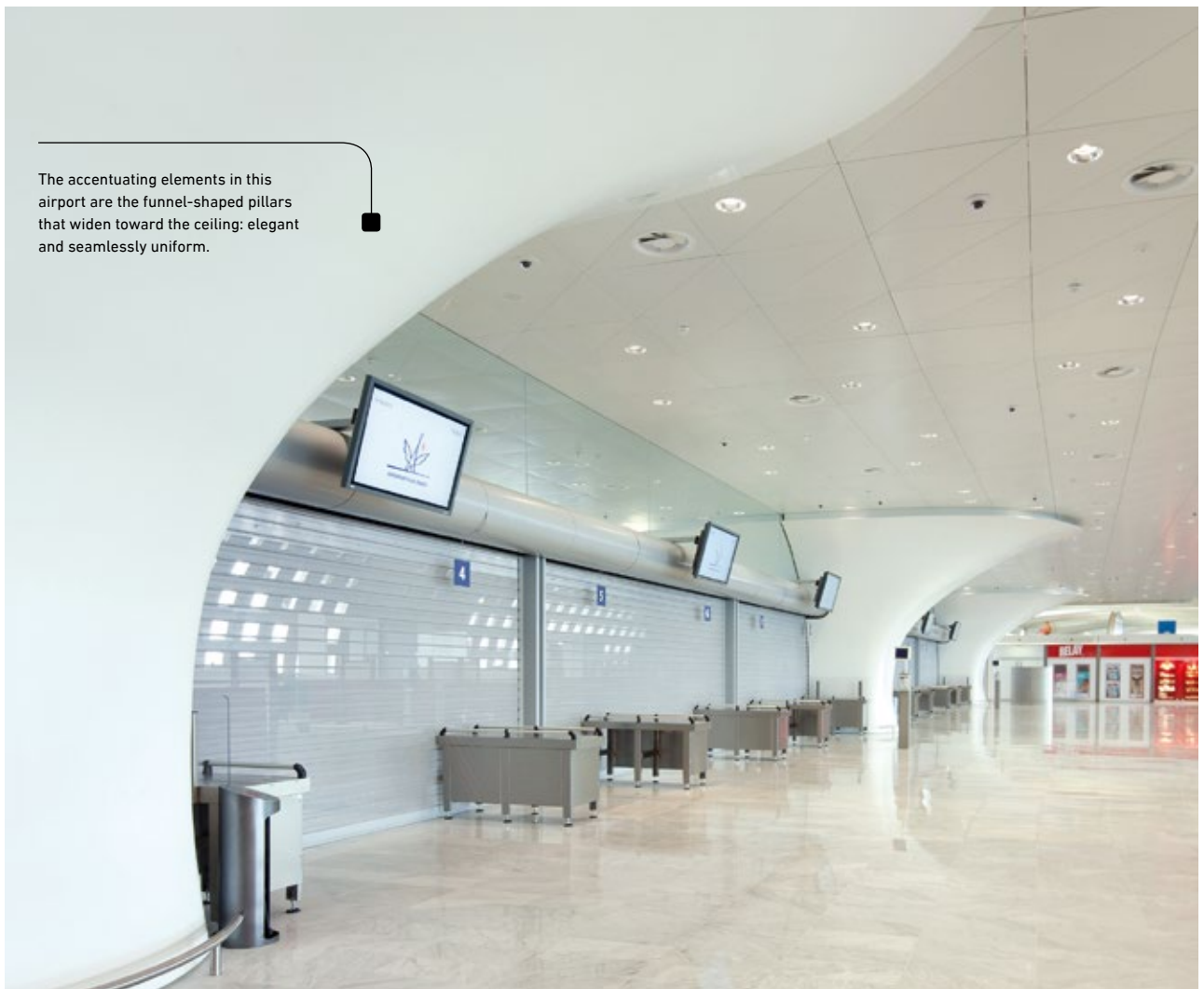

The accentuating elements in this airport are the funnel-shaped pillars that widen toward the ceiling: elegant and seamlessly uniform.

Project: Column cladding at Airport Paris Charles de Gaulle, France – Design: Marc Fidelle and Andrei David, Direction de l'Ingénierie et de l'Architecture d'Aéroports de Paris – Fabrication: LCCA – Photo: Mathieu Ducros

Airports

Counters, shelves and other surfaces at airports are exposed to heavy loads, constant touching and high traffic. This is why they must be manufactured from an extremely durable material which is both easy to clean and smooth and pleasant to the touch. HI-MACS® fits the bill: with this high-quality mineral material, installations will look as good as new for years to come.



Project: MY Selena – Design: Wim van der Valk Continental – Fabrication: Bone Solid / Baars & Bloemhoff – Photo: Jeffrey de Bie

Marine industry

HI-MACS® is becoming more and more popular in the shipbuilding industry. On the one hand because the material is ideal for high-demand installations; on the other hand, because it meets essential criteria such as those for fire resistance and low flame propagation. A special formula of HI-MACS®, HI-MACS® FR, has been recognised for its excellence in this area with a Module B and D IMO certificate from the Marine Equipment Directive.

Educational institutions

HI-MACS® is a favourite in universities and schools because of its visually seamless finish and non porous, sanitary surface. An independent laboratory has confirmed that the material's hygienic properties comply with international LGA and NSF standards.



Project: Newcastle University Student's Union, UK – Design: FaulknerBrowns Architects – Fabrication: Multi-Surface Fabrications Ltd – Photo: Cadzow Pelosi

Healthcare

HI-MACS® is the material of choice in hospitals and laboratories thanks to its internationally certified resistance to dirt, viruses, bacteria and many chemicals. In addition to these sanitary advantages, the material boasts a number of other benefits including extreme durability and excellent value for money.



The perfect material for using horizontally or vertically
A sink and counter in white with furniture facings in an elegant anthracite: all effortless to keep hygienic and clean.

Project: Aesthetic medical centre Imaderm – Design: Patrice Reynaud Architectes – Fabrication: RS Agencement Steiner SA, kläusler acrylstein ag – Photo: Blaise Lambert



Hygienic and lovely in shape

Perfect hygiene is an important factor when working in the medical field. When 3D formation is skilfully applied and mixed with emotional lighting, even a physician's practice can be turned into an impressive experimental space like this one.

Project: Dental Clinic smileDentity, Germany – Design: Hubert Günther – Fabrication: Tischlerei Woodstar – Photo: Ralf Baumgartner

It was the "long lasting quality" as well as the beauty of HI-MACS® that can be perfectly matched with their recent wood colours that made the designers of the renowned Swedish furniture manufacturer Karl Andersson & Söner select HI-MACS® as the key-material for two of their new collections.



Project: BUFF, CERCO – Design: Table Buff design by Joel Karlsson, Shelf Cerco design by Federico Churba – Fabrication: Karl Andersson & Söner – Photo: Jonas Sällberg

Furniture design

Both classic and contemporary design ideas can be implemented thanks to the extensive colour palette, translucency and virtually limitless design flexibility of "Natural Acrylic Stone". The end results are creations that would be impossible to achieve with conventional materials.

The main advantages. At a glance.

The following properties make HI-MACS® stand out as the material of the "New Generation":

- Virtually unlimited **range of applications**
- Countless possibilities for customized design (colour, formability, translucency, etc.)
- Valuable, **laboratory-tested** raw materials
- **Advanced manufacturing techniques**
- High-quality processing technology
- **Ecological** commitment
- **Wide range** of sinks and bowls
- **Ease of maintenance** thanks to dirt-repellent surfaces
- **Resistance** to common household chemicals
- **Resistance** to bacteria and viruses
- **Fire resistance** and low flame propagation properties
- Excellent **value for money**
- **15 Year Warranty**, which is the only one of its kind on the market

Sinks & Bowls

Every option is available to designers to create neat washrooms, kitchens, hospitals and much more with our wide range of HI-MACS® sinks and bowls. Perfectly coordinated and ideal for mixing and matching, the bowls and sinks guarantee a modern look that is easy and simple to look after.



HI-MACS® Bowls for bathrooms (top mount installation)

These three new shapes are HI-MACS® answer to the trend of straight-lined designs. All three bowls are exclusively designed for top mount installations. The tight radiuses of the two rectangular versions lead to exceptionally spacious bowls. The slim but robust side walls add an elegant contemporary look to these shapes.

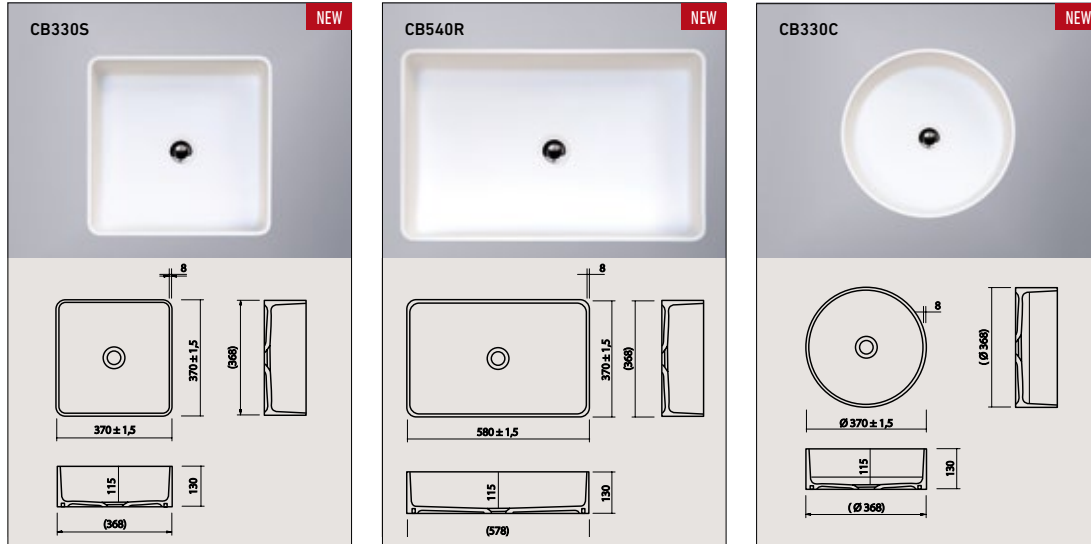

HI-MACS® Bowls for bathrooms

HI-MACS® bowls offer superb ease of cleaning and a warm and pleasant feel, making them the ideal solution for creating the bathroom of your dreams. They are manufactured using a casting process and ideally suited for both flush mounting and installation into a bathroom vanity top.

HI-MACS® Baby Bath

Nothing less than the maximum level of hygiene, ergonomics and warmth is good enough for the neonatal ward of any hospital. With ultra-soft corners and contours ergonomically designed specifically for babies, the new HI-MACS® Baby Bath is the perfect product for babies' first baths of their lives.



HI-MACS® sinks and HI-MACS® washstands are available in Alpine White S028 and Nougat Cream S201.

HI-MACS® Baby Bath is available only in Alpine White S028.

Warranty: 15 years on all precast HI-MACS® bowls, sinks and baby bath.

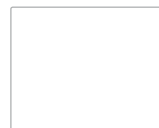

Alpine White
S 028

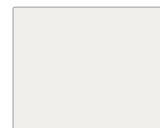

Nougat Cream
S 201

Minimum order quantities apply:
S001, S002, S005, S006,
S009, S029, S033

HI-MACS® Sinks for kitchens and laboratories

HI-MACS® sinks are produced using a high-quality casting technique.

No matter which product you choose from our extensive, eminently combinable selection, all sinks are flush-mounted into the countertop or installed below the surface. Special custom-made creations are also an option.

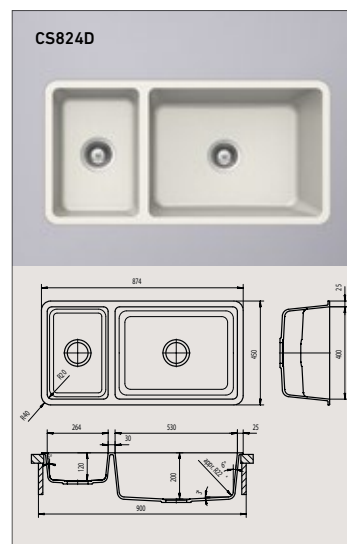
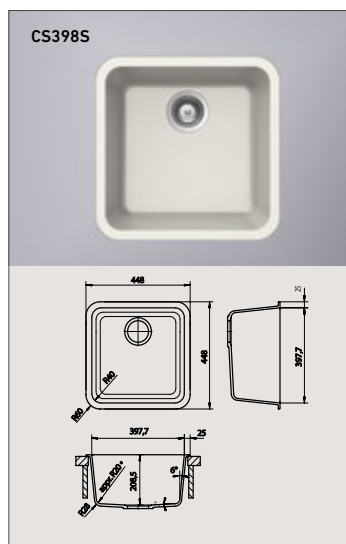
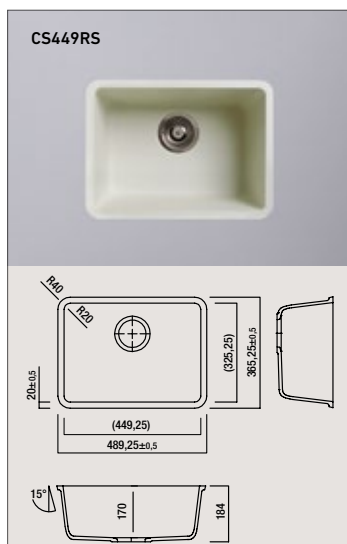
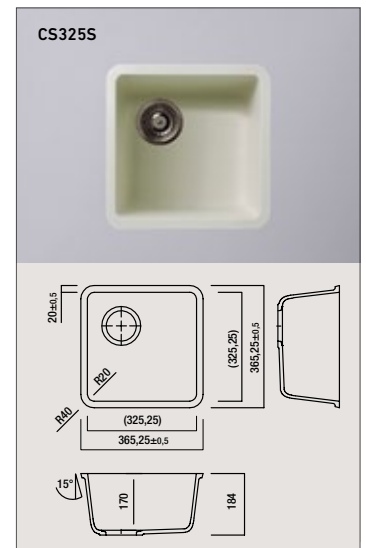
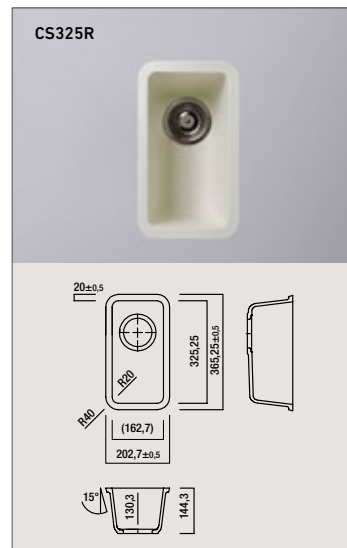
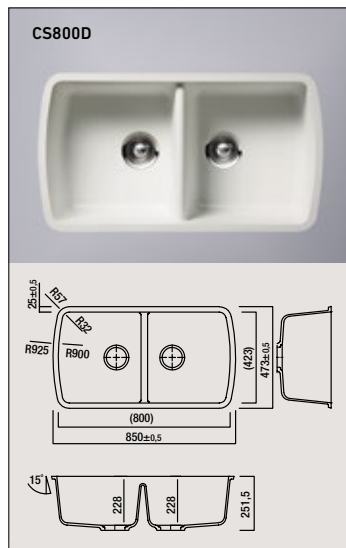
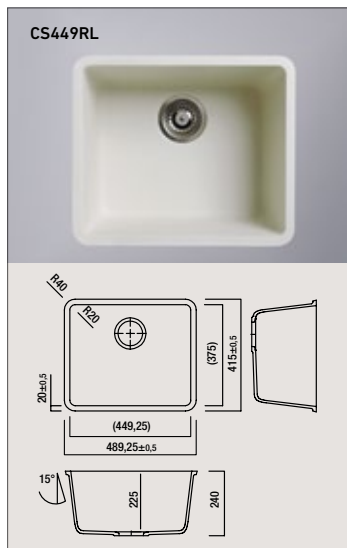
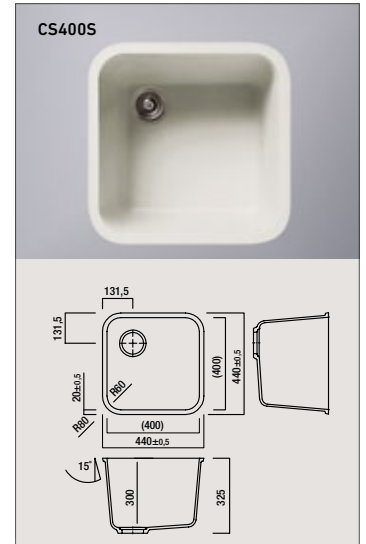
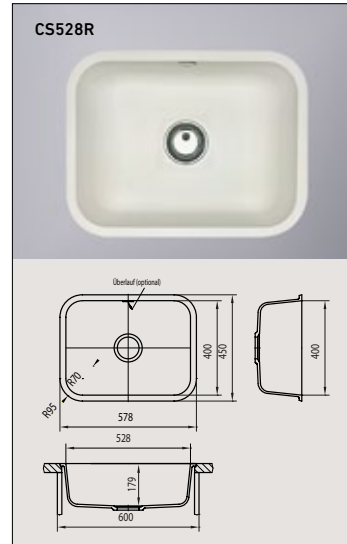
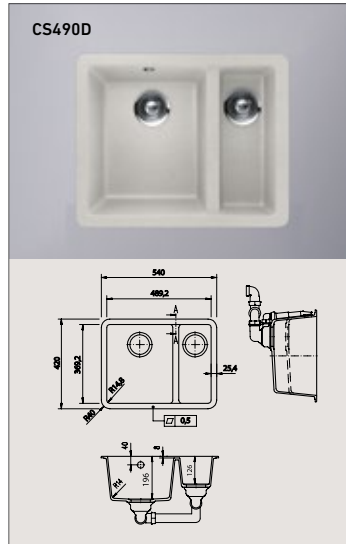
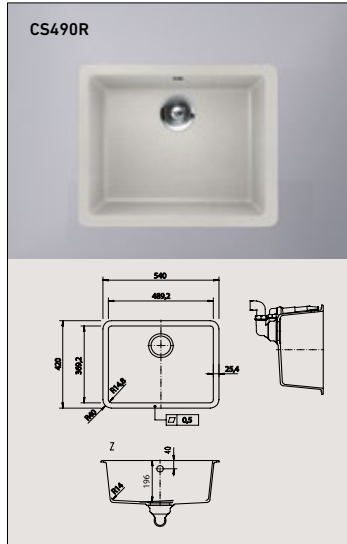

Dimensions – Sheet material

Standard Format

SHEET THICKNESS IN MM	SHEET WIDTH IN MM	SHEET LENGTH IN MM
3	930	3000 *
6	760	2490
6	910	2490 *
9	760	3680
9	910	3680 *
12	760	3680
12	910	3680 *
12	1350	3680 *
19	760	3680 *

* Only available in S028 Alpine White.

** Only available in S001 Satin White, S005 Grey, S006 Arctic Granite, S009 Cream, S022 Black, S025 Fiery Red, S104 Toffee Brown, S201 Nougat Cream.

*** Only available in S028 Alpine White and S006 Arctic White.

**** Only available in Solid colours.

Special Format

SHEET THICKNESS IN MM	SHEET WIDTH IN MM	SHEET LENGTH IN MM
3	930	3000 **
6	910	2490 ***
9	910	3680 ***
12	910	3680 ***
12	1350	3680 ***
19	760	3680 ****

Size matters –

to increase efficiency and reduce offcuts

HI-MACS® can be supplied in different sheet thicknesses, formats and sizes. Ideal for maximum cutting, minimum wastage and minimal costs. However, not all colours are available in all thicknesses. Please see the colour charts on the following pages for exact availability.

HI-MACS® fire resistant quality significantly widens the fields of application

HI-MACS® FR-version sheets are available in S728 Alpine White and manufactured to order in S801 Nougat Cream, S729 Ivory White, S706 Arctic White and S705 Grey.

Sheets in S728 Alpine White comply with the IMO Standard Modules B+D and M1. FR sheets are especially suitable for use in public buildings, external facades and in the marine industry.

Chemical resistance

HI-MACS® is a fully homogenous material with no pores and is thus simple and easy to clean.

TEST SUBSTANCE	APPLICATION TIME	EVALUATION OF G02 CHANGES	EVALUATION OF S06 CHANGES
Acetic acid	16h	no change	no change
Citric acid	16h	no change	no change
Sodium carbonate	16h	no change	no change
Ammonium hydroxide	16h	no change	no change
Ethyl alcohol	16h	no change	no change
White wine, red wine	16h	no change	no change
Beer	16h	not tested	not tested
Cola drinks	16h	no change	no change
Instant coffee	16h	no change	no change
Black Tea	16h	no change	no change
Blackcurrant juice	16h	no change	no change
Cream	16h	no change	no change
Water	16h	no change	no change
Petrol	16h	no change	no change
Acetone	16h	3	3
Ethyl butyl acetate	16h	3	3
Butter	16h	no change	no change
Olive Oil	16h	no change	no change
Mustard	16h	no change	no change
Salt	16h	no change	no change
Onions	16h	no change	no change
Lipstick	16h	no change	no change
Common household disinfectant	16h	no change	no change
Black pen – ballpoint	16h	2	2 – 3
Stamping ink	16h	1	1
Cleaning agent	16h	no change	no change
Cleaning solution	16h	no change	no change
Wear resistance group according to DIN 68861*	16h	1B	1B
Evaluation according to DIN 68930 Table 1 Other work surfaces: wear resistance group: «1C»		Requirement met +	according to DIN 68861 & DIN 68930

* 1A = Excellent; 1F = very bad 0 = no visible result; 5 = damaged

Technical data sheet

HI-MACS® is extremely repellent to dirt and wear and tear, so that you can enjoy many years of pleasure with the outstanding quality of your new product.

SPECIFICATION	UNIT	RESULT		TEST METHODS
		SOLIDS	GRANITE	
Flexural-E-modulus	MPa	8900	7730	DIN EN ISO 178
Flexural strength	MPa	70.1	64.3	ASTM D638
Breaking elongation	%	1	1.1	DIN EN ISO 178
Tensile strength	MPa	69.5	56.3	DIN EN ISO 527
Density	g/cm ³ kg/m ³	1.75 1750	1.65 1650	ISO 1183 ISO 1183
Ball indentation hardness	N/mm ²	257	239	DIN EN ISO 2039-1
Mohs hardness		2 to 3	2 to 3	EN 101
Pencil hardness		>9H	>9H	ISO 15184
Water absorption weight strength/thickness		<0,1% <0,1%	<0,1% <0,1%	DIN EN 438 Part 12
Impact resistance impactor drop ball test (fall height)	N mm	≥25 ≥1500	≥25 ≥1500	E DIN EN 438, 02/02 Part 2/20 E DIN EN 438, 02/02 Part 2/21
Slip resistance		>0,32 – 0,9		GMG100 (replaces R9)
Slip resistance		angle of acceptance of more than 10° to 19° = R10		DIN 51130
Climate change resistance	°C	≥0,05	≥0,05	AMK
Dry heat (pan base)	°C	≥100 (7C)		DIN 68 861, Part 7, 04-'85
Damp heat (pan base)	°C	≥100 (7C)		DIN 68 861, Part 8, 04-'85
Temperature change resistance	°C	no change		UNI 9429
Resistance to cigarette burns		6C	6B	DIN 68 861, Part 6, 11-'82
Scratch resistance		4D	4B	DIN 68 861, Part 4, 11-'81
Electrostatics Conductivity	>1x10 ¹² Ω	insulating non-conductive		DIN IEC 1340-4-1, 04-'92 EN 61340-5-1
Thermal conductivity	W/mK	0.636	0.55	DIN EN 12664
Thermal resistance	m ² K/W	0.038	0.045	DIN EN 12664
Thermal expansion co-efficient	mm/mK m/m/°C	0.048 30.0 x 10 ⁻⁶	0.055	DIN EN 14581
Water vapor transmission properties – diffusion resistance factor	μ	18607	16150	DIN EN ISO 12572
Dimensional change by change in relative humidity length thickness mass	% % %	-0.03 0.06 0.05	-0.02 0.03 0.05	DIN EN 318, edit. 5, 1998
Resistance to boiling water increase in weight increase in thickness	% %	<0,1 <0,1	>0,1 <0,1	E DIN EN 438, 02/02 Part 2/12
Light fastness (Xenon)	scale 0 – 10	better than 6	better than 6	DIN 53 387, 04-'89
Food tolerance		suitable for all colours		LMBG § 31
Hygiene		suitable	suitable	LGA Hygiene Certificate
Fire protection classification Flame-retardant properties MPA/NRW HI-MACS® MPA/NRW (BAM) 12 mm (BAM) 9 mm + back-up (Bodycote/Warrington) 12 mm		B1 non-dripping material B1 for all colours* B1 for all colours* B-s1 , d0 for all HI-MACS® colours* complies with BS 476 class 0		DIN 4102-1 DIN 5510 DIN 4102-1 BS EN ISO 11925-2 : 2002 BS EN 13823: 2002
* not currently applicable to Marmo, Galaxy, Volcanics, Lucent and Eden				

Colours

Colours are key in design. Elegant Nordic White, warm Toffee Brown or mystical Cima.

We have whatever colour you want – it's your choice.

Extra service on demand

If needed, LG Hausys Europe can produce different dimensions and bespoke colours. To learn more about the conditions, please contact us on himacs.eu



NEW Lucia

Natural trendy colours characterised by linear-edged, midsize particles: three of those curated by Dutch Star Designer, Marcel Wanders.

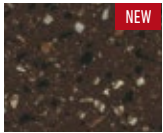

Red Quinoa *
W010 [12 mm]



Lentil
W007 [12 mm]

Three colours
designed by
Marcel Wanders:



Ice Queen
W001 [12 mm]



Shadow Queen
W003 [12 mm]



Star Queen *
W004 [12 mm]



Volcanics

Full of depth and mysticism, akin to a precious natural stone but with all of the advantages of "Natural Acrylic Stone™".



Gemini
VW001 [12 mm]



Tambora
VE001 [12 mm]



Santa Ana
VA001 [12 mm]

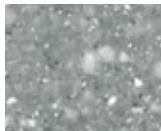

Frosty
VA022 [12 mm]



Maui
VG021 [12 mm]



Taos *
VB021 [12 mm]



Cima *
VB002 [12 mm]

Marmo

You will be captivated by its random veined texture, reminiscent of marble.



Bologna
M103 [12 mm]



Roma *
M104 [12 mm]



Verona *
M105 [12 mm]

Lucent

When combined with precisely positioned light sources, the translucent pastel shades become transformed into dramatic design "highlights".

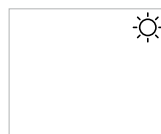

Opal
S302 [12/6 mm]
Δ E4

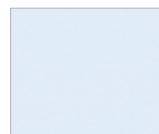

Sapphire
S303 [12 mm]

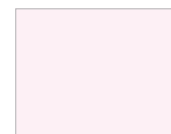

Ruby
S304 [12 mm]

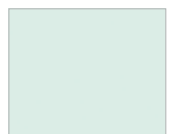

Emerald
S305 [12 mm]

Solids

From elegant to extravagant, classic to ultra-contemporary – this is a limitless collection.



Nordic White
S033 [19/12 mm]
Δ E4



Alpine White
S028 [19/12/9/6/3 mm]
Δ E3



Diamond White
S034 [19/12 mm]
Δ E4

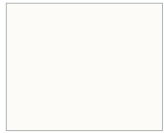

Arctic White
S006 [19/12/9/6/3 mm]
Δ E4



Ivory White
S029 [19/12/9/6 mm]
Δ E4



Satin White
S001 [19/12/9/6/3 mm]



Cream
S009 [19/12/6/3 mm]
Δ E3



Nougat Cream
S201 [19/12/3 mm]

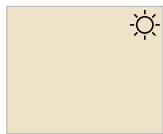

Almond
S002 [19/12 mm]
Δ E3



Babylon Beige
S102 [19/12 mm]



Concrete Grey *
S103 [19/12 mm]



Toffee Brown *
S104 [19/12/3 mm]



Marta Grey *
S108 [19/12 mm]



Light Green *
S212 [19/12 mm]



Lemon Squash *
S106 [19/12 mm]



Banana *
S26 [19/12 mm]



Orange *
S027 [19/12 mm]



Fiery Red *
S025 [19/12/3 mm]



Festival Pink *
S116 [19/12 mm]



Steel Grey *
S109 [19/12 mm]



Grey
S005 [19/12/9/6/3 mm]



Midnight Grey *
S117 [19/12 mm]



Sky Blue
S203 [19/12 mm]



Deep Indigo *
S115 [19/12 mm]



Dark Night *
S111 [19/12 mm]



Coffee Brown *
S100 [19/12 mm]



Black *
S022 [19/12/9/3 mm]

19 mm: S028 Alpine White available in stock. All other solid colours minimum quantities apply.
3 mm: S028 Alpine White available in stock. S001 Satin White, S006 Arctic White, S009 Cream, S104 Toffee Brown, S005 Grey, S201 Nougat Cream, S025 Fiery Red and S022 Black minimum quantities apply.

Aster (Galaxy)

With transparent grains and mother of pearl shimmer, as if from another world.

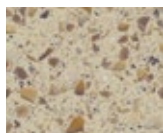

Uranus
T002 [12 mm]



Nebula
T010 [12 mm]

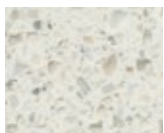

Venus
T011 [12 mm]

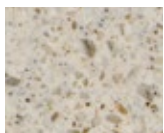

Mars
T016 [12 mm]

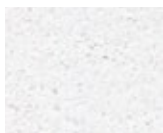

Andromeda
T017 [12 mm]



Carina
T018 [12 mm]

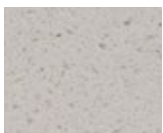

New Moon
T019 [12 mm]



Hercules *
T020 [12 mm]

The basic HI-MACS® material is identical for every colour but it is important to note that darker and more heavily pigmented colours will show dust, scratches, haziness, marks left by hard water and other ordinary wear and tear more noticeably than lighter textured colours. Therefore colours marked with a * are less suitable for applications that are exposed to extensive surface contact such as work-tops located in heavy traffic area as an example.

Due to specific characteristics and properties of the Marmo colours, which have a veined effect, special consideration has to be taken into account with jointing and the use of covered up-stands. Veining may vary from sheet to sheet.

There may be deviations between the illustrated and actual colours owing to printing techniques.

To receive the detailed colour range, please contact us at himacs.eu.

☼ Some HI-MACS® colours are particularly suitable for outdoor applications because of their good UV-resistance. HI-MACS® offers a 5 Year Warranty on colours' UV resistance for a tolerance of ΔE3 to ΔE4 and loss of gloss over 40%, 10 Year Warranty on colour leaching and 20 Year Warranty on colour peeling, swelling or delaminating. The warranty is applicable after the first installation and is only valid for the sheet material; adhesives are excluded. The conditions for this warranty are based on practical experience and on-going tests.

Granite, Sparkle, Quartz, Sand & Pearl

A huge selection of textures and colours. Natural, elegant and perfect to combine.



Arctic Granite
G034 [12/9/6 mm],
Δ E3

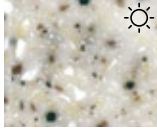

White Granite
G005 [12 mm]
Δ E4



Natural Granite
G023 [12/9 mm]

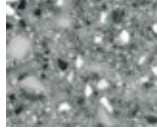

Grey Granite
G017 [12 mm]



Platinum Granite
G007 [12 mm]

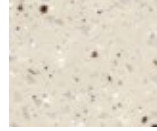

Grey Crystal
G102 [12 mm]



Peanut Butter
G100 [12 mm]



Mocha Granite
G074 [12 mm]



Black Granite *
G031 [12/9 mm]

Sparkle colours
designed by
Karim Rashid:



Kreemy Grey
P101 [12 mm]



Kold Silver
P102 [12 mm]

himacs



White Quartz
G004 [12/9/6 mm],
Δ E4



Crystal Beige
G101 [12 mm]



Moonscape Quartz
G058 [12 mm]



Sea Oat Quartz
G038 [12 mm]
Δ E3



Allspice Quartz
G063 [12 mm]

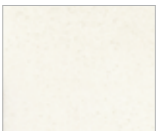

Lunar Sand
G108 [12/9 mm]

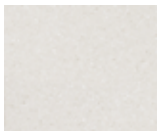

Pebble Pearl
G107 [12 mm]



Riviera Sand
G106 [12/9 mm]



Beach Sand
G048 [12/9 mm]
Δ E3

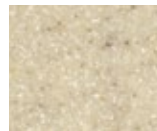

Almond Pearl
G008 [12 mm]



Desert Sand
G001 [12 mm]



Tapioca Pearl
G050 [12 mm]

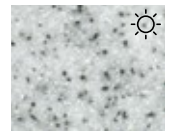

Grey Sand
G002 [12/6 mm]
Δ E4



Brown Pearl *
G105 [12 mm]



Midnight Pearl *
G015 [12 mm]



Black Pearl *
G010 [12/6 mm]



Black Sand
G009 [12 mm]

A strong partner. For your boldest ideas.

Architects, designers and artisans appreciate HI-MACS® as a competent partner capable of taking on any challenge. We are happy to advise you during the planning and development phase and assist you in the successful implementation of your project. We have experienced representatives throughout Europe who can provide you with active support. Contact us today!

himacs.eu

Eden

A one-of-a-kind palette with warm natural shades and various grain sizes.

What makes the collection unique: it consists of up to 35% recycled materials.

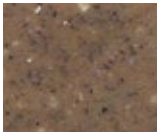

Cocoa
G501R [12 mm]
12% Recycled Content

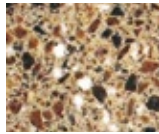

Sugar Maple
G510R [12 mm]
35% Recycled Content

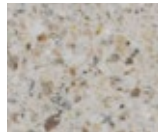

Poplar
G511R [12 mm]
35% Recycled Content

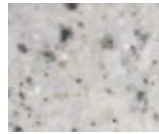

Birch Bark
G514R [12 mm]
35% Recycled Content

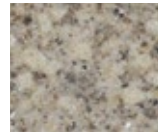

Pecan
G515R [12 mm]
35% Recycled Content

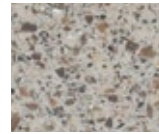

Hickory
G516R [12 mm]
35% Recycled Content

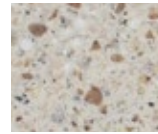

Mountain Ash
G517R [12 mm]
35% Recycled Content

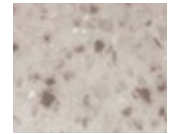

Ripe Cotton
G518R [12 mm]
12% Recycled Content

The Eden collection is available upon special request. More information about this range and its environmental benefits can be found on pages 8 and 9 of this brochure.

Scoring eco-credits across the board.

The LEED (Leadership in Energy and Environmental Design) seal is a proven classification system for ecological, resource saving and sustainable construction. The credit-based certification process rates buildings according to different criteria. Opting for HI-MACS® Eden in new construction and renovation projects may provide up to 2 credits in the following LEED categories:

Indoor Environmental Quality (IEQ)

LEED IEQ 4.1: low-emission materials, adhesives and sealants (1 credit)

Materials & Resources (MR)

LEED MR 4.1: materials with more than 10% recycled content (1 credit)

LEED MR 4.2: materials with more than 20% recycled content (2 credits)

We would be pleased to provide you with details and information.

HI-MACS®. The New Generation.

LG Hausys Europe GmbH
Lyoner Str. 15
60528 Frankfurt
Germany
Tel: +49 (0)69 583029463
Fax: +49 (0)69 66113506

himacs.eu



HI-MACS® and Natural Acrylic Stone™ are registered trademarks of LG Hausys Europe GmbH. All other trademarks and product names are trademarks or registered trademarks of their respective rights owners. The information contained in this brochure is intended to be for information only and can be amended at any time without prior notification. ©2016. LG Hausys Europe GmbH. All rights reserved.

Publisher's Details

Thomas Andenmatten, thomasandenmatten.ch | Valter Baldan, fotobaldan.it | Baars & Bloemhoff, baars-bloemhoff.nl | Ralf Baumgarten, ralfbaumgarten.de | Felix Bembe & Sebastian Dellinger, bembe-dellinger.de | Berceli, berceli.com | Kovovyroba Blecha, kovoblecha.sk | Bone Solid, bonesolid.nl | Zoey Braun Fotografie, zoeybraun.de | Jeffrey de Brie, revontuli.nl | Faulkner Browns, faulknerbrowns.co.uk | Fusteria Castelló, fusteriacastello.com | Federico Churba, federicochurba.com.ar | COAST Office Architecture, coastoffice.de | Delugan-Meisssl Associated Architects, deluganmeissl.at | diephotodesigner.de, diephotodesigner.de | Dominic Obertreis, obertreis.de | Karl Dreer GmbH, dreer-gmbh.de | Mathieu Ducros, mathieuducros.com | Elft bvba, elft.be | FaulknerBrowns Architects, faulknerbrowns.co.uk | oettle ferber associates, oettleferber.com | David Franck, davidfranck.de | Focal Foto, focalfoto.com | GRAICHEN Bau- und Möbelwerkstätten GmbH, graichen-gmbh.de | Hubert Günther, pd-raumplan.de | Zaha Hadid Architects, zaha-hadid.com | Joke Holvoet, elft.be | Kaden Klingbeil, kaden-klingbeil.de | Karl Andersson & Söner, karl-andersson.se | Kiebitzberg GmbH & Co.KG, kiebitzberg.de | kläusler acrylstein ag, himacs.ch | Klöpfer Surfaces, kloepfer-surfaces.de | Mgr. Art. Kristina Krempova, kristinadesign.webnode.cz | Schreinerei Lell, schreinerei-lell.de | Blaise Lambert, images-aeriennes.com | LG Collection AB, lgcoll.se | LCCA, lcca.fr | Marco Podrini, studiopodrini.com | Multi-Surface Fabrications, thesolidsurfacespecialists.co.uk | Cadzow Pelosi cadzowpelosi.com | Pfeiffer GmbH & Co KG, pfeiffer-germany.de | PurPur GmbH, purpur.de | RafaCub, rafacub.com | Bureau Patrice Reynaud Architectes, reynaud.ch | Studio Podrini, studiopodrini.com | Thorsten Ruppert, thorstenruppert.com | Realinox, S.L., realinox.com | Roman Skyba, romanskyba.sk | Paul Schad Tischlerei GmbH, schad-trier.de | RS Agencement Steiner SA, rs-steiner.ch | Frederik Verccruyse, frederikverccruyse.be | Matthias Werlen Architektur AG, tiso.ch | Dirk Wilhelmy Fotografie, dirkwilhelmy.com | Wim van der Valk Continental, wimvandervalk.com | Tischlerei Woodstar, tischlerei-woodstar.de | Zeiter+ Berchtold AG, zeiter-berchtold.ch